

SPEED CONTROLLERS

The speed controller is installed on actuators such as cylinders and air motors, and controls the operating speed of the actuator by adjusting the flow through the actuator.

SC6	Standard type	Rc 1/4 ~ 1
-----	---------------	------------

SC213	Standard type	Rc 1 1/4 ~ 50A Flange
-------	---------------	-----------------------

SC6F	Fine-tuning type	Rc 3/8
------	------------------	--------

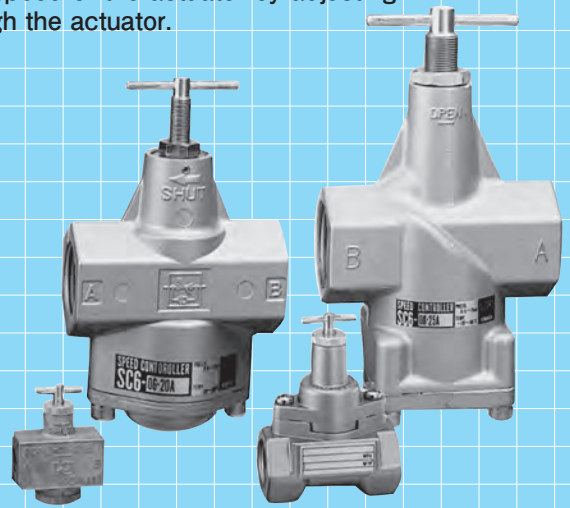
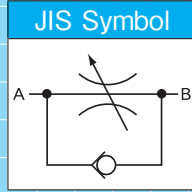

Model Code

When ordering, specify the model as follows:

Standard type

Rc 1/4 ~ 3/8

SC6 1 - 02 - 2 - 7

• Corrosion-resistant • Port size • Operating temperature range

Rc 1/4 ~ 1/2

SC6 1 - 04 - 3 - 7

• Corrosion-resistant • Port size • Operating temperature range

Rc 1/2 ~ 3/4

SC6 1 - 06 - 4 - 7

• Corrosion-resistant • Port size • Operating temperature range

Rc 3/4 ~ 1

SC6 1 - 08 - 5 - 7

• Corrosion-resistant • Port size • Operating temperature range

Rc 1 1/4 ~ 50A Flange

SC213 1 - 6

• Corrosion-resistant • Port size

Fine-tuning type

Rc 3/8

SC6F 1 - 02 - 10A - 7

• Corrosion-resistant • Operating temperature range

1 Corrosion-resistant

- Portions that are exposed to outside weather conditions are corrosion-resistant coating and the exposed bolts, nuts and brackets are stainless steel.

Standard	No entry
Corrosion-resistant type	S

2 Body size and Port size

02	Rc1/4	8A
	Rc3/8	10A

3 Body size and Port size

04	Rc1/4	8A
	Rc3/8	10A
	Rc1/2	15A

4 Body size and Port size

06	Rc1/2	15A
	Rc3/4	20A

5 Body size and Port size

08	Rc3/4	20A
	Rc1	25A

6 Port size

Rc 1 1/4	32A
Rc 1 1/2	40A
50A Flange	50A

7 Operating temperature range

General purpose	-20 ~ 60°C	No entry
Heat-resistant	5 ~ 100°C	HT
Freeze-resistant	-40 ~ 45°C	LT

- For corrosion, freeze resistant type, allow some margin for delivery.
- Freeze resistant type is not available for 04 body size.
- In operating temperatures of 5°C or less, provide adequate measures against freezing.

Speed Controllers

Specifications

Standard type

Model code		SC6-02		SC6-04			SC6-06		SC6-08		SC213		
Port size		8A	10A	8A	10A	15A	15A	20A	20A	25A	32A	40A	50A
		Rc1/4	Rc3/8	Rc1/4	Rc3/8	Rc1/2	Rc1/2	Rc3/4	Rc3/4	Rc1	Rc1 1/4	Rc1 1/2	Flange
Effective sectional area	Max. controlled flow	10mm ²	25mm ²	32mm ²	72mm ²	150mm ²	170mm ²	310mm ²	360mm ²	1,050mm ²			
	Free flow	12.5mm ²	30mm ²	38mm ²	90mm ²	152mm ²	172mm ²	210mm ²	260mm ²	840mm ²			
Operating pressure		0.05 ~ 0.7MPa											
Proof pressure		1.05MPa											
Cracking pressure		0.05MPa or less											
Operating temperature range		General purpose			- 20 ~ 60°C						5 ~ 60°C		
		Heat-resistant			5 ~ 100°C								
		Freeze-resistant			- 40 ~ 45°C								
Mass		0.1kg	0.15kg			0.36kg		0.8kg		3.3kg	4.0kg	27.5kg	

Fine-tuning type

Model code		SC6F-02			
Port size		10A			
		Rc3/8			
Effective sectional area	Max. controlled flow	0.8mm ²			
	Free flow	12.5mm ²			
Operating pressure		0.05 ~ 0.7MPa			
Proof pressure		1.05MPa			
Cracking pressure		0.05MPa 以下			
Operating temperature range		General purpose		- 20 ~ 60°C	
		Heat-resistant		5 ~ 100°C	
		Freeze-resistant		- 40 ~ 45°C	
Mass		0.1kg			

● For specifications other than those listed above, please contact us.

Operation

Standard type SC6 – 04 – 15A

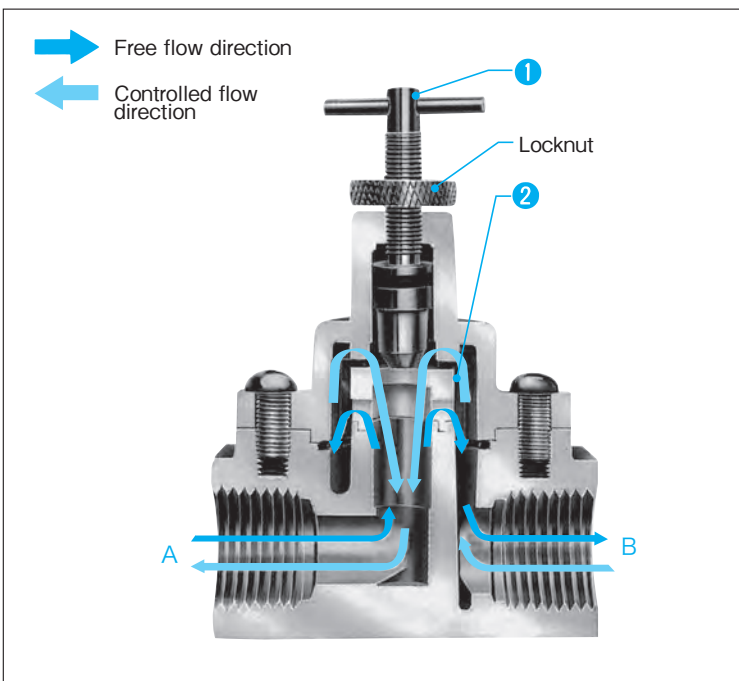

1 Adjusting screw

[In the case of SC6-02, SC6-04 and SC6-06]

With controlled flow, turning the handle clockwise reduces the flow ; turning it counterclockwise increases it.

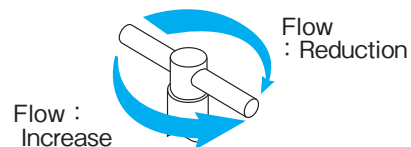

※ In the case of SC6-08 and SC213, the reverse operations are performed.

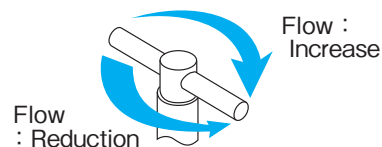

2 Valve

Has the function of a check valve and is formed of synthetic rubber. For free flow, the valve is opened by air pressure from port A ; for controlled flow, it is closed by air pressure from port B.

Outside Dimensions

Standard and Fine-tuning type

SC6-02-8A · 10A
SC6F-02-10A

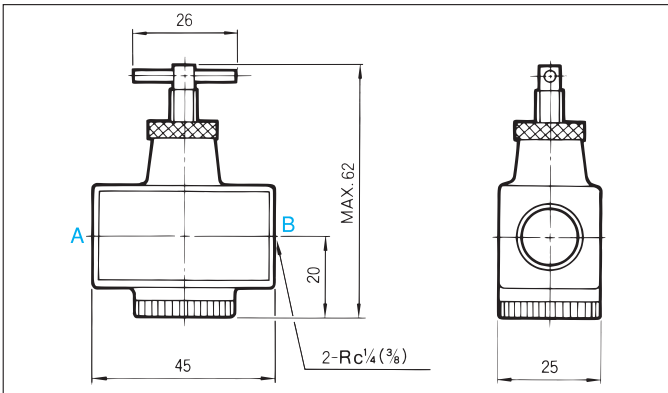

SC213-32A

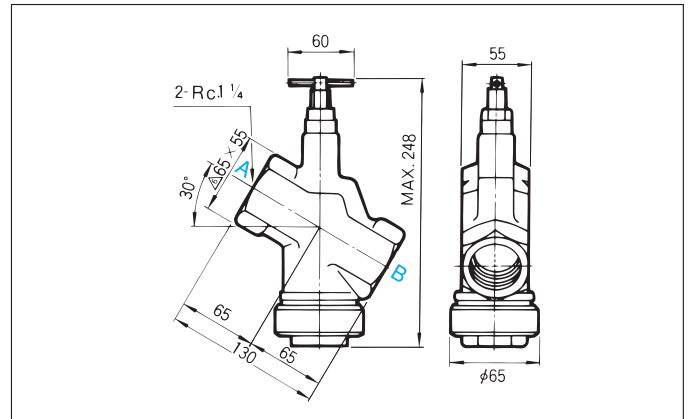

SC6-04-8A · 10A · 15A

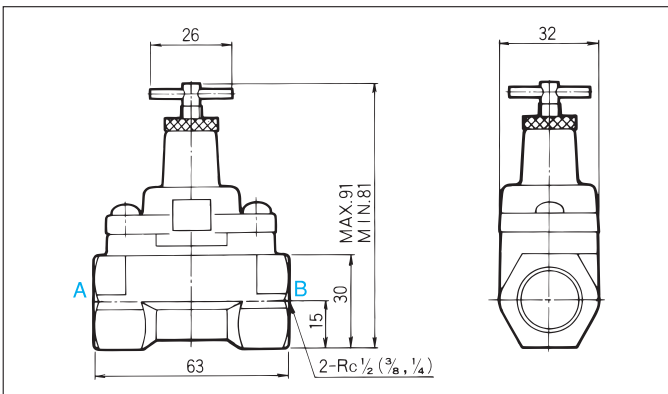

SC213-40A

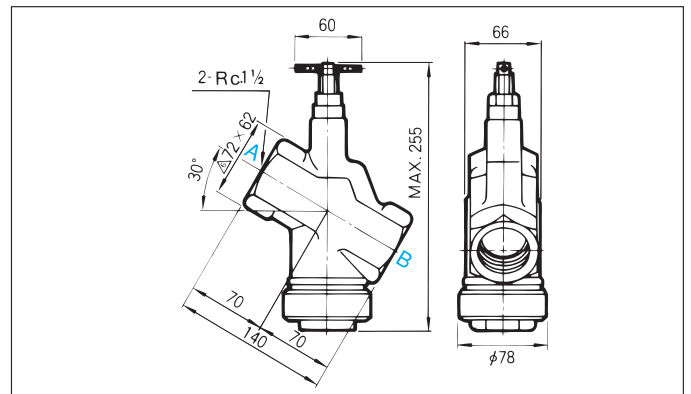

SC6-06-15A · 20A

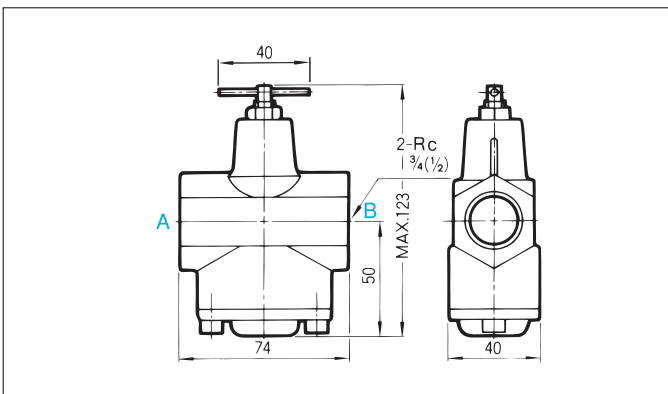

SC213-50A

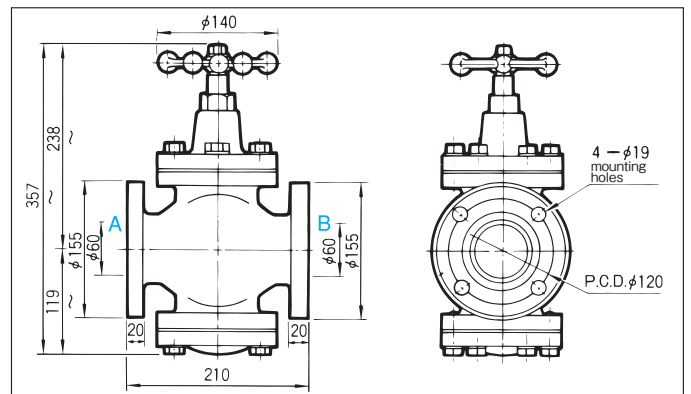

SC6-08-20A · 25A

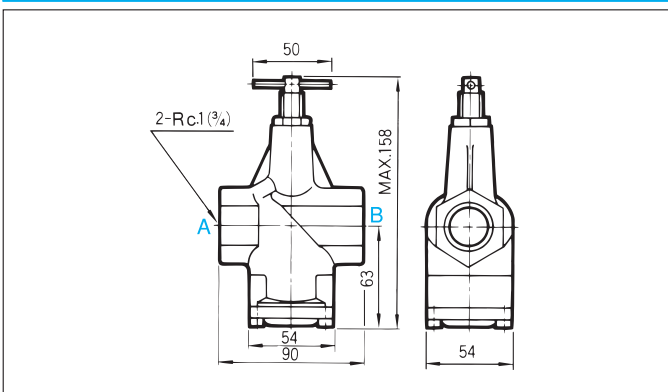



Speed Controllers

Performance Tables

Flow characteristics graphs for controlled (flow from ports B to A)

Standard type

SC6-02-8A · 10A

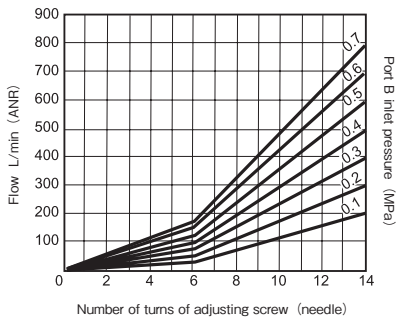

SC6-08-20A · 25A

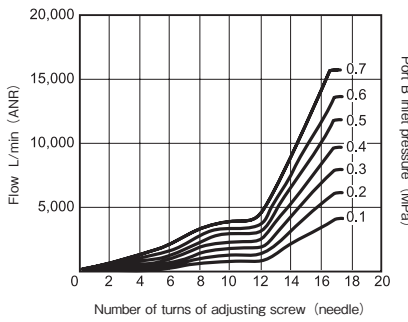

Fine-tuning type

SC6F-02-10A

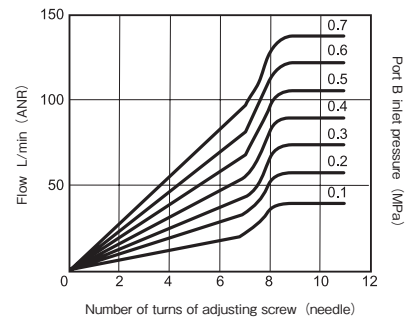

SC6-04-8A

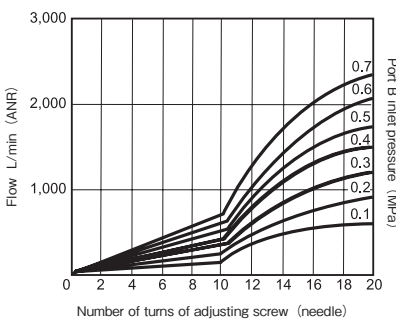

SC213-32A

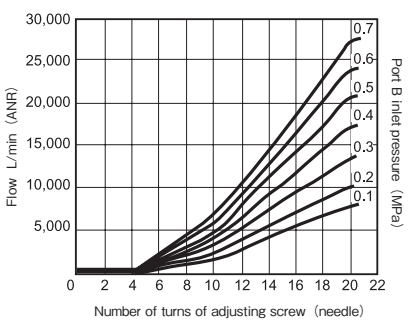

SC6-04-10A · 15A

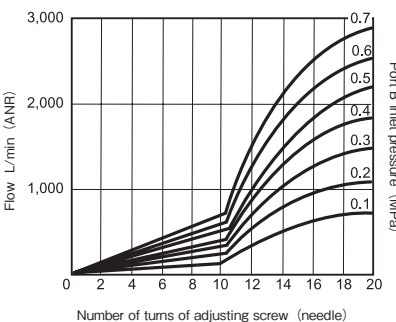

SC213-40A

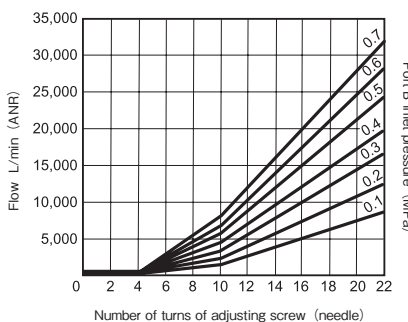

SC6-06-15A · 20A

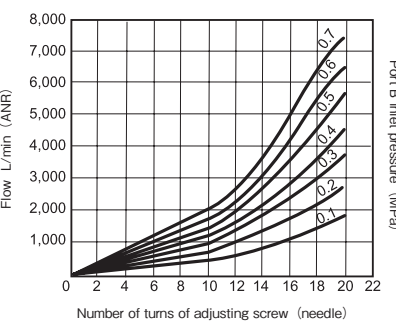

SC213-50A

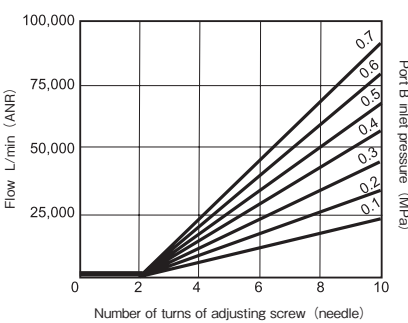

Performance Tables

Flow characteristics graphs for free flow (from ports A to B)

Standard and Fine-tuning type

SC6-02-8A · 10A
SC6F-02-10A

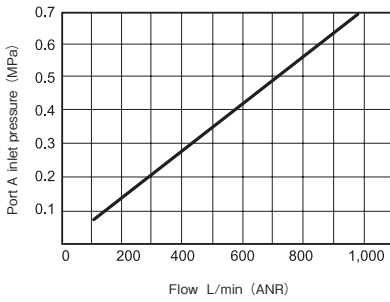

SC6-06-15A · 20A

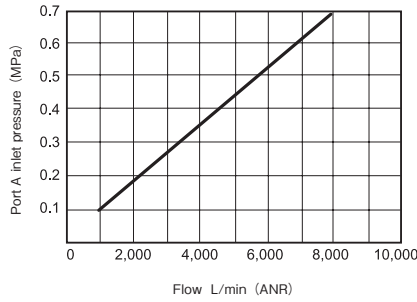

SC213-32A

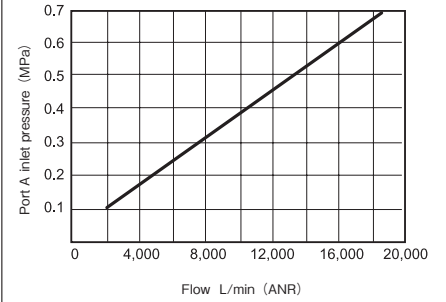

SC6-04-8A

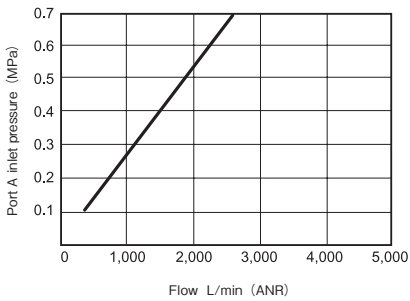

SC6-08-20A

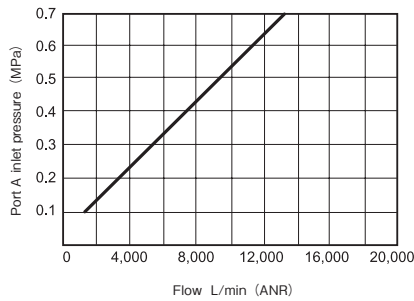

SC213-40A

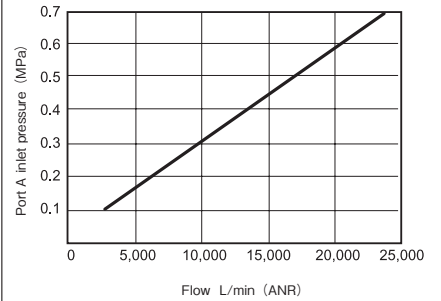

SC6-04-10A · 15A

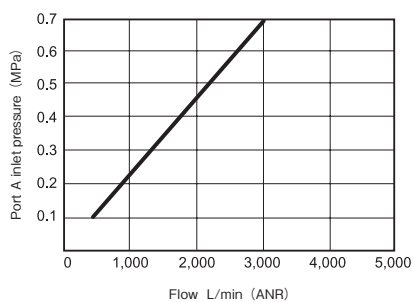

SC6-08-25A

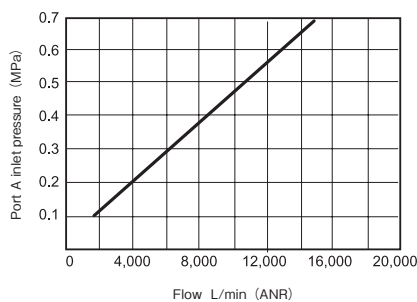

SC213-50A

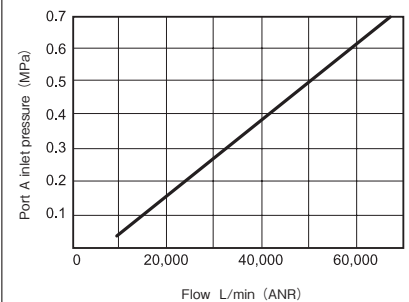



Speed Controllers

Operating Instructions

1 Fluid

- Since dirt, dust, wastes, etc. in the fluid may cause malfunctioning, use only clean fluid.

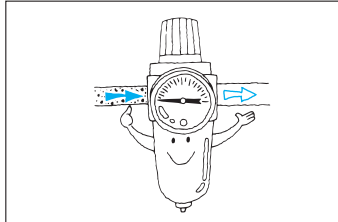

2 Circuit to be used

- In the most extensively used speed control method, the speed controller is installed so that the exhaust flow from actuators such as cylinders can be reduced (meter-out system).
- Sometimes, the speed controller is installed so that the supply flow to the actuator can be reduced (meter-in system). Generally speaking, the meter-out system provides a more stable speed control.

Meter-out system

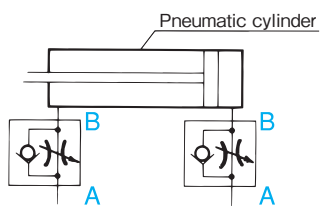

Omnidirectional, Screwed SPEED CONTROLLERS

SC7

Standard type

^{RC} 1/8 · 1/4 · 3/8

This speed controller can be mounted directly on air cylinders. It is a compact, L-shaped design that can be connected to the pipe at any angle (360°) and is suitable for use in a meter-out system.

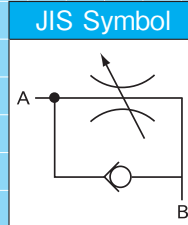

Model Code

When ordering, specify the model as follows:

SC7 - 1

● Port size

※ Port A = female Rc thread.
Port B = male R thread.

1 Port size

R.Rc1/8	06A
R.Rc1/4	08A
R.Rc3/8	10A

Specifications

Model code		SC7-06A	SC7-08A	SC7-10A
Port size		6A	8A	10A
		R1/8 · Rc1/8	R1/4 · Rc1/4	R3/8 · Rc3/8
Effective sectional area	Max. controlled flow	5.5mm ³	8.3mm ³	14.0mm ³
	Free flow	3.8mm ³	11.0mm ³	16.0mm ³
Operating pressure		Max. 0.7MPa		
Proof pressure		1.05MPa		
Operating temperature		5 ~ 60°C		
Number of turns of needle valve available		8 turns		
Mass		0.04kg	0.07kg	0.1kg



Outside Dimensions

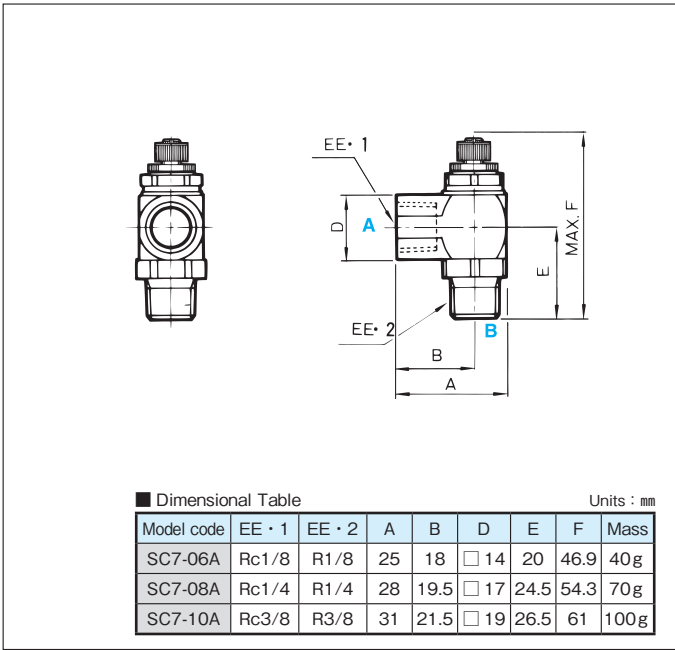

Performance Tables

Flow characteristics graphs for controlled flow (from ports B to A)

SC7-06A

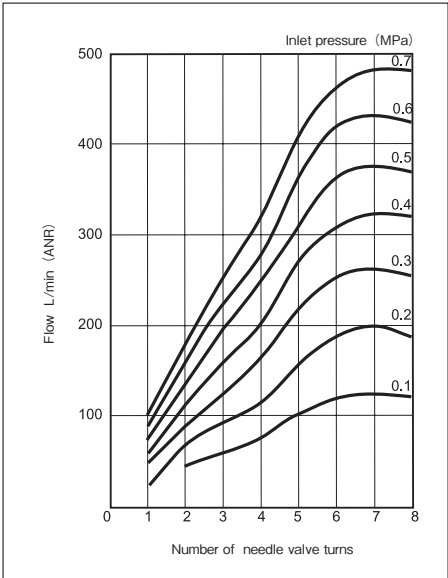

SC7-08A

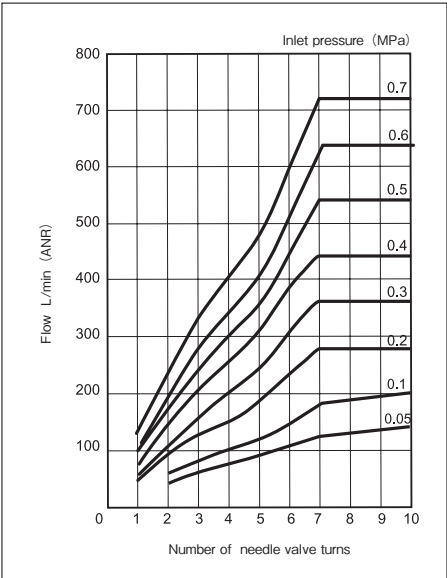

SC7-10A

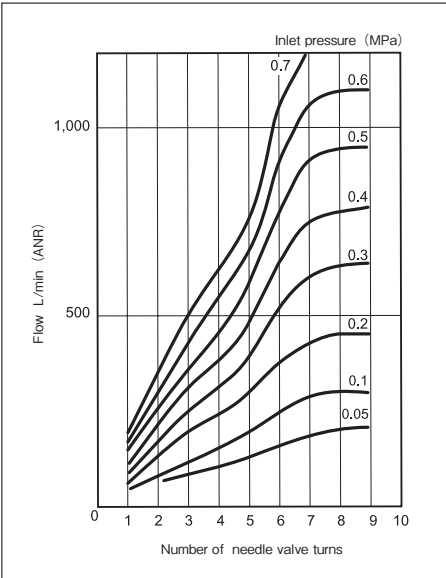

Performance Tables

Flow characteristics graphs for free flow (from ports A to B)

SC7-06A

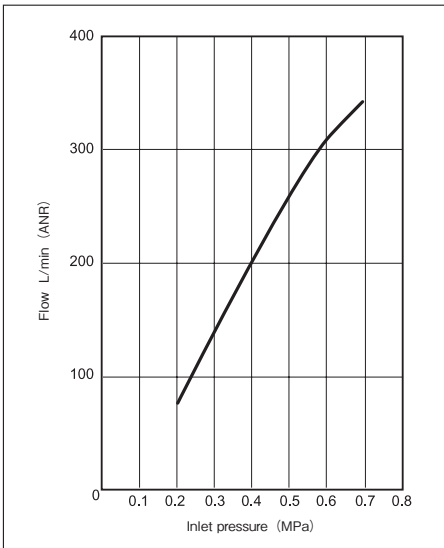

SC7-08A

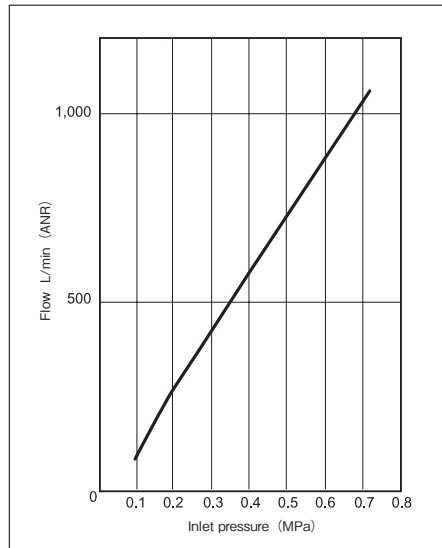

SC7-10A

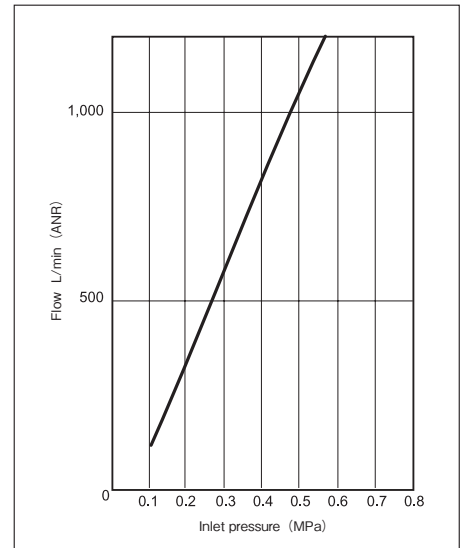

Operating Instructions

1 Fluid

- Since dirt, wastes, etc. in the fluid may cause malfunctioning. Use only clean fluids.

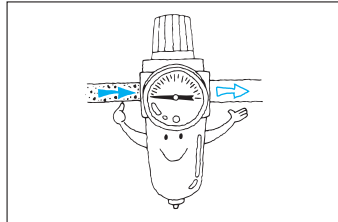

2 Piping

- Limit the number of threads screwed in the pipe connection of actuators, air cylinders, etc., to four or five sizes 6A to 10A (R1/8" to 3/8"). If the controller is forced beyond that point, the mating device or the controller body will crack, causing trouble.

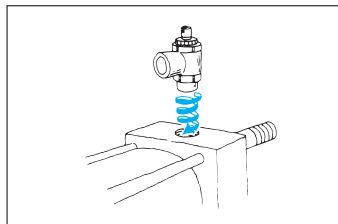

Omnidirectional, One-touch SPEED CONTROLLERS

Standard miniature type	M3 × 0.5 · M5 × 0.8 · R ¹ / ₈
B (Flexidle) miniature type	M3 × 0.5 · M5 × 0.8 · R ¹ / ₈
Standard type	M5 × 0.8 · R ¹ / ₈ · 1/4 · 3/8 · 1/2
B (Flexidle) type	M5 × 0.8 · R ¹ / ₈ · 1/4 · 3/8 · 1/2

The speed controllers are available in two types, normal standard type with a freely rotating body, and a flexible type that permits tube connection at any angle. An extensive variety of pipe diameters (male thread sizes) are provided, ranging from the miniature type (M3-Rc1/8) to standard type (M5-Rc1/2).

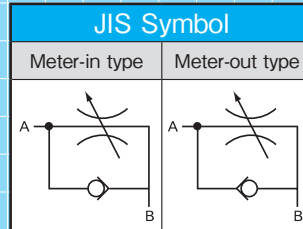

Features

Compact design

- The compact speed controllers come with a built-in "FUJI" touch connector.

Swivel threaded portion

- With the standard type, the body and threaded portion are free to rotate, allowing the tube to be connected at any angle. With the B type, the body and perpendicular portion rotate freely, permitting connection of the flexible tube at any angle.

Superior flow characteristics

- Fine tuning of the flow presents no difficulties, even in a low flow range.

A wide variety of tubing materials

- Choices available include polyurethane, polyamide, polyethylene and PTFE, depending on the application.

Optional indicator rings available in six colors

- The indicator rings allow visual distinction between lines in a complicated piping system for easy assembly and maintenance.

Missing needle preventive mechanism

Sealant-processed for connection screw port

Non-electrolytic plated finish for metal portion (miniature type)

Specifications

Model code	Same format for all types
Operating pressure	Max. 0.7 MPa
Proof pressure	1.05 MPa
Operating temperature	5 ~ 60°C
Applicable tube material	Polyurethane, nylon, polyethylene, PTFE

Model Code

When ordering, specify the model as follows. Please order it by ten units.

Standard miniature type

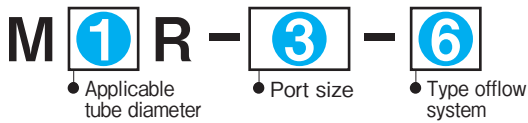

B (Flexible) miniature type



Standard type



B (Flexible) type

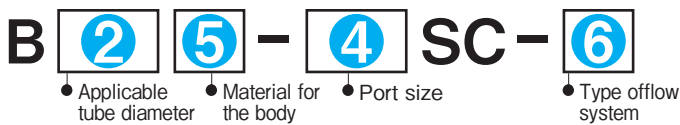

1 Applicable tube diameter	
4mm	4
6mm	6

3 Port size	
M3 × 0.5	M3
M5 × 0.8	M5
R1/8	01

5 Material for the body	
Metal	No entry
Resin	R

● Please note that no M3 screws are manufactured for speed controllers with a 6mm tube size

● Please note that no resin-made body is manufactured for speed controllers with a 4mm tube size.

2 Applicable tube diameter	
4mm	4
6mm	6
8mm	8
10mm	10
12mm	12

4 Port size	
M5 × 0.8	M5
R 1/8	01
R 1/4	02
R 3/8	03
R 1/2	04

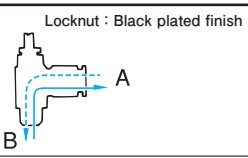
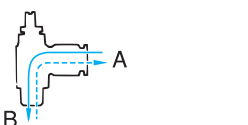
6 Type of flow system		
Meter-in type		I
Meter-out type		O

● An example of model code

- Standard type
- Applicable tube size : 6mm
- Body material : Resin
- Thread size : R 1/4
- Type of flow system : Meter-in

6R-02SC-I



Construction/Outside Dimensions

Standard miniature type

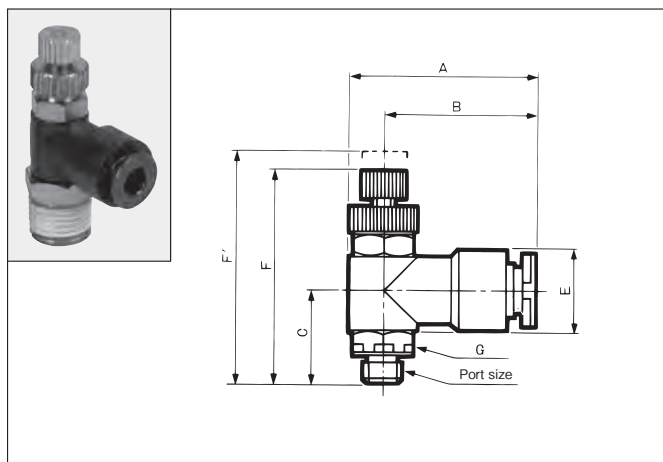
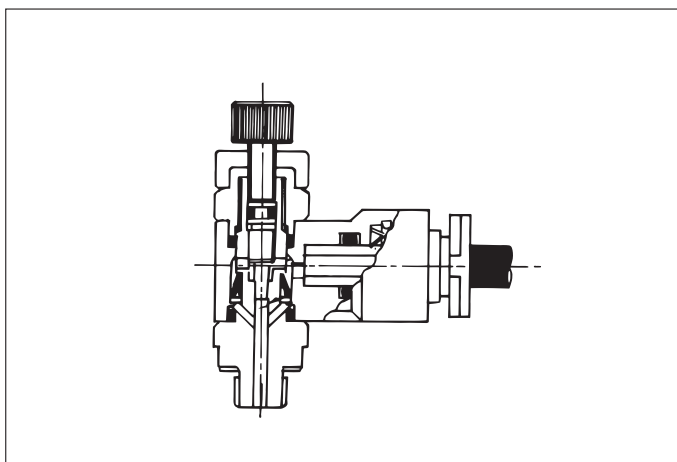

Dimensional Table

Model code		Port size	Applicable tube	Dimensions (mm)							Material for the body	Mass (g)
Meter-in type	Meter-out type			A	B	C	E	F	F'	G		
M4R-M3-I	M4R-M3-O	M3 × 0.5	TP-4 · TN-4	25.2	20.7	13	φ11	29.1	31.5	8	Polyacetal · Metal	9.0
M4R-M5-I	M4R-M5-O	M5 × 0.8	TP-4 · TN-4	25.2	20.7	14	φ11	30.1	32.5	8		10.0
M4R-01-I	M4R-01-O	R1/8	TP-4 · TN-4	25.7	20.7	16.5	φ11	32.6	35	10		13.0
M6R-M5-I	M6R-M5-O	M5 × 0.8	TP-6 · TN-6	27.7	23.2	15	φ13	30.1	32.5	8		11.5
M6R-01-I	M6R-01-O	R1/8	TP-6 · TN-6	28.2	23.2	17.5	φ13	32.6	35	10		14.0

● "TP" of the applicable tube represents polyurethane and "TN" nylon. ● Dimension "G" represents the subtense of a hexagon.

Construction/Outside Dimensions

B (Flexidle) miniature type

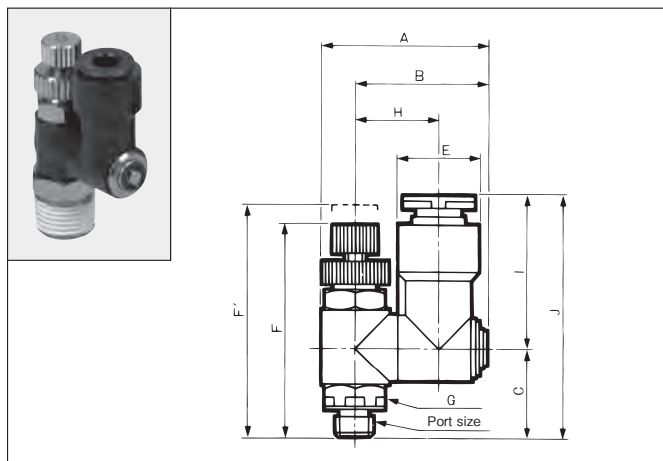
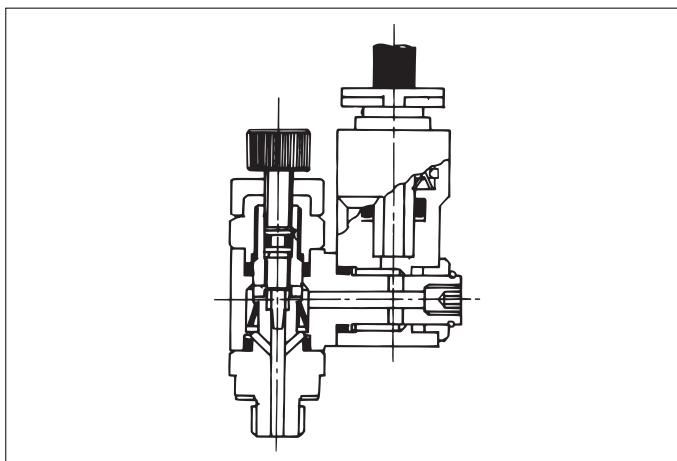

Dimensional Table

Model code		Port size	Applicable tube	Dimensions (mm)										Material for the body	Mass (g)
Meter-in type	Meter-out type			A	B	C	E	F	F'	G	H	I	J		
MB4R-M3-I	MB4R-M3-O	M3 × 0.5	TP-4 · TN-4	21.9	17.4	12.5	φ11	29.1	31.5	8	11.3	20.7	33.2	Polyacetal · Metal	10.5
MB4R-M5-I	MB4R-M5-O	M5 × 0.8	TP-4 · TN-4	21.9	17.4	13.5	φ11	30.1	32.5	8	11.3	20.7	34.2		11.5
MB4R-01-I	MB4R-01-O	R1/8	TP-4 · TN-4	22.4	17.4	16	φ11	32.6	35	10	11.3	20.7	36.7		14.5
MB6R-M5-I	MB6R-M5-O	M5 × 0.8	TP-6 · TN-6	23.3	18.8	13.5	φ13	30.1	32.5	8	12.3	23.2	36.7		12.5
MB6R-01-I	MB6R-01-O	R1/8	TP-6 · TN-6	23.8	18.8	16	φ13	32.6	35	10	12.3	23.2	39.2		15.5

● "TP" of the applicable tube represents polyurethane and "TN" nylon. ● Dimension "G" represents the subtense of a hexagon.

Construction/Outside Dimensions

Standard type

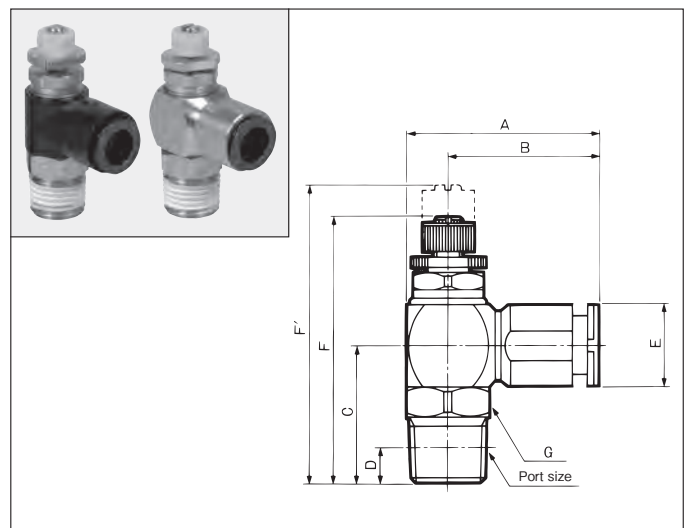
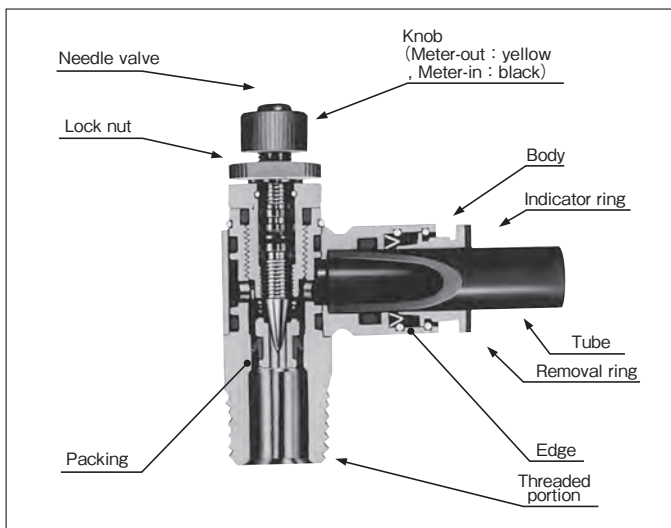

Dimensional Table

Model code		Port size	Applicable tube	Dimensions (mm)								Material for the body	Mass (g)
Meter-in type	Meter-out type			A	B	C	D	E	F	F'	G		
6R-M5SC-I	6R-M5SC-O	M5 × 0.8	TP-6 · TN-6	29.7	23.2	16.4	—	φ13	36.2	39.3	12	Polyacetal · Metal	20.0
6R-01SC-I	6R-01SC-O	R1/8	TP-6 · TN-6	29.7	23.2	19.5	4	φ13	39.3	42.4	12		22.0
6R-02SC-I	6R-02SC-O	R1/4	TP-6 · TN-6	29.7	23.2	22.5	6	φ13	42.3	45.4	14		27.5
8R-01SC-I	8R-01SC-O	R1/8	TP-8 · TN-8	33.6	26.1	20.5	4	φ15	41.9	46.9	14		30.5
8R-02SC-I	8R-02SC-O	R1/4	TP-8 · TN-8	33.6	26.1	23.5	6	φ15	44.9	49.9	14		35.5
8R-03SC-I	8R-03SC-O	R3/8	TP-8 · TN-8	33.6	26.1	24.5	6.5	φ15	45.9	50.9	17		43.0
10R-02SC-I	10R-02SC-O	R1/4	TP-10 · TN-10	37.1	28.1	24.5	6	φ17	48.3	54.3	17		51.0
10R-03SC-I	10R-03SC-O	R3/8	TP-10 · TN-10	37.1	28.1	25.5	6.5	φ17	49.3	55.3	17		58.0
10R-04SC-I	10R-04SC-O	R1/2	TP-10 · TN-10	37.1	28.1	29.5	8	φ17	53.3	59.3	21		76.0
12R-03SC-I	12R-03SC-O	R3/8	TP-12 · TN-12	41.1	30.6	27	6.5	φ20	52	61	19		75.0
12R-04SC-I	12R-04SC-O	R1/2	TP-12 · TN-12	41.1	30.6	31	8	φ20	56	65	21		93.0
4-M5SC-I	4-M5SC-O	M5 × 0.8	TP-4 · TN-4	28.1	22.1	15.9	—	φ11	36.2	39.3	12		Metal
4-01SC-I	4-01SC-O	R1/8	TP-4 · TN-4	28.1	22.1	19	4	φ11	39.3	42.4	12	30.5	
6-M5SC-I	6-M5SC-O	M5 × 0.8	TP-6 · TN-6	29.2	23.2	15.9	—	□12	36.2	39.3	12	29.5	
6-01SC-I	6-01SC-O	R1/8	TP-6 · TN-6	29.2	23.2	19	4	□12	39.3	42.4	12	32.0	
6-02SC-I	6-02SC-O	R1/4	TP-6 · TN-6	29.2	23.2	22	6	□12	42.3	45.4	14	37.5	
8-01SC-I	8-01SC-O	R1/8	TP-8 · TN-8	32.6	25.6	20	4	□14	41.9	46.9	14	44.0	
8-02SC-I	8-02SC-O	R1/4	TP-8 · TN-8	32.6	25.6	23	6	□14	44.9	49.9	14	48.5	
8-03SC-I	8-03SC-O	R3/8	TP-8 · TN-8	32.6	25.6	24	6.5	□14	45.9	50.9	17	56.5	
10-02SC-I	10-02SC-O	R1/4	TP-10 · TN-10	36.6	28.1	24.5	6	□17	48.3	54.3	17	74.0	
10-03SC-I	10-03SC-O	R3/8	TP-10 · TN-10	36.6	28.1	25.5	6.5	□17	49.3	55.3	17	81.0	
10-04SC-I	10-04SC-O	R1/2	TP-10 · TN-10	36.6	28.1	29.5	8	□17	53.3	59.3	21	99.0	
12-03SC-I	12-03SC-O	R3/8	TP-12 · TN-12	40.1	30.6	26.5	6.5	□19	52	61	19	105.5	
12-04SC-I	12-04SC-O	R1/2	TP-12 · TN-12	40.1	30.6	30.5	8	□19	56	65	21	123.0	

● "TP" of the applicable tube represents polyurethane and "TN" nylon.



Construction/Outside Dimensions

B (Flexidle) type

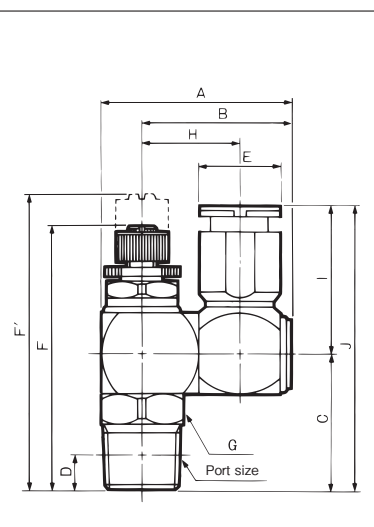
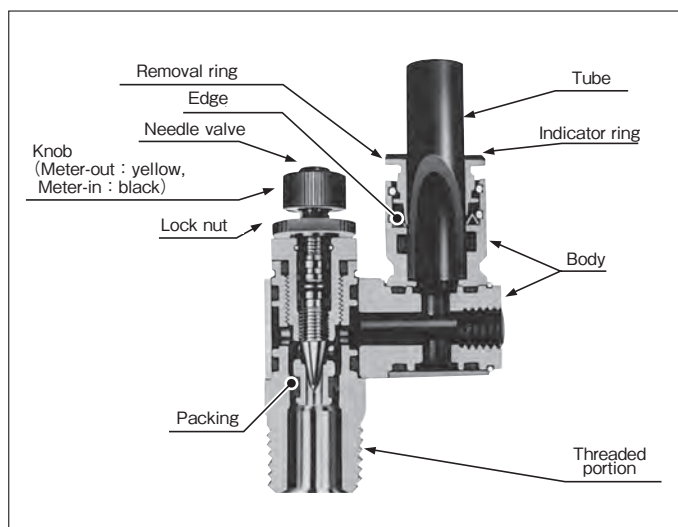

Dimensional Table

Model code		Port size	Applicable tube	各部サイズ (mm)										Material for the body	Mass (g)	
Meter-in type	Meter-out type			A	B	C	D	E	F	F'	G	H	I			J
B6R-M5SC-I	B6R-M5SC-O	M5 × 0.8	TP-6 · TN-6	28.5	22	15.9	—	φ13	36.2	39.3	12	14.5	23.2	39.1	Polyacetal · Metal	22.5
B6R-01SC-I	B6R-01SC-O	R1/8	TP-6 · TN-6	28.5	22	19	4	φ13	39.3	42.4	12	14.5	23.2	42.2		25.0
B6R-02SC-I	B6R-02SC-O	R1/4	TP-6 · TN-6	28.5	22	22	6	φ13	42.3	45.4	14	14.5	23.2	45.2		30.5
B8R-01SC-I	B8R-01SC-O	R1/8	TP-8 · TN-8	33	25.5	20	4	φ15	41.9	46.9	14	17	26.1	46.1		34.5
B8R-02SC-I	B8R-02SC-O	R1/4	TP-8 · TN-8	33	25.5	23	6	φ15	44.9	49.9	14	17	26.1	49.1		39.5
B8R-03SC-I	B8R-03SC-O	R3/8	TP-8 · TN-8	33	25.5	24	6.5	φ15	45.9	50.9	17	17	26.1	50.1		47.5
B10R-02SC-I	B10R-02SC-O	R1/4	TP-10 · TN-10	39.9	30.9	24.5	6	φ17	48.3	54.3	17	20.2	28.1	52.6		58.5
B10R-03SC-I	B10R-03SC-O	R3/8	TP-10 · TN-10	39.9	30.9	25.5	6.5	φ17	49.3	55.3	17	20.2	28.1	53.6		65.0
B10R-04SC-I	B10R-04SC-O	R1/2	TP-10 · TN-10	39.9	30.9	29.5	8	φ17	53.3	59.3	21	20.2	28.1	57.6		83.5
B12R-03SC-I	B12R-03SC-O	R3/8	TP-12 · TN-12	43.4	32.9	26.5	6.5	φ20	52	61	19	21.7	30.6	57.1		85.5
B12R-04SC-I	B12R-04SC-O	R1/2	TP-12 · TN-12	43.4	32.9	30.5	8	φ20	56	65	21	21.7	30.6	61.1		103.5
B4-M5SC-I	B4-M5SC-O	M5 × 0.8	TP-4 · TN-4	28	22	15.9	—	φ11	36.2	39.3	12	14	22.1	38	Metal	42.0
B4-01SC-I	B4-01SC-O	R1/8	TP-4 · TN-4	28	22	19	4	φ11	39.3	42.4	12	14	22.1	41.1		44.5
B6-M5SC-I	B6-M5SC-O	M5 × 0.8	TP-6 · TN-6	28	22	15.9	—	□12	36.2	39.3	12	14	23.2	39.1		43.5
B6-01SC-I	B6-01SC-O	R1/8	TP-6 · TN-6	28	22	19	4	□12	39.3	42.4	12	14	23.2	42.2		45.5
B6-02SC-I	B6-02SC-O	R1/4	TP-6 · TN-6	28	22	22	6	□12	42.3	45.4	14	14	23.2	45.2		51.5
B8-01SC-I	B8-01SC-O	R1/8	TP-8 · TN-8	32.5	25.5	20	4	□14	41.9	46.9	14	16.5	25.6	45.6		65.5
B8-02SC-I	B8-02SC-O	R1/4	TP-8 · TN-8	32.5	25.5	23	6	□14	44.9	49.9	14	16.5	25.6	48.6		70.5
B8-03SC-I	B8-03SC-O	R3/8	TP-8 · TN-8	32.5	25.5	24	6.5	□14	45.9	50.9	17	16.5	25.6	49.6		78.0
B10-02SC-I	B10-02SC-O	R1/4	TP-10 · TN-10	39.4	30.9	24.5	6	□17	48.3	54.3	17	20.2	28.1	52.6		112.5
B10-03SC-I	B10-03SC-O	R3/8	TP-10 · TN-10	39.4	30.9	25.5	6.5	□17	49.3	55.3	17	20.2	28.1	53.6		119.0
B10-04SC-I	B10-04SC-O	R1/2	TP-10 · TN-10	39.4	30.9	29.5	8	□17	53.3	59.3	21	20.2	28.1	57.6		137.0
B12-03SC-I	B12-03SC-O	R3/8	TP-12 · TN-12	42.4	32.9	26.5	6.5	□19	52	61	19	21.2	30.6	57.1		153.5
B12-04SC-I	B12-04SC-O	R1/2	TP-12 · TN-12	42.4	32.9	30.5	8	□19	56	65	21	21.2	30.6	61.1		171.5

● "TP" of the applicable tube represents polyurethane and "TN" nylon.

Performance Tables

Flow characteristics graphs

Miniature type

For controlled flow

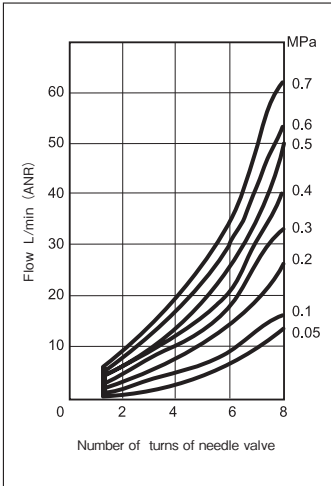

For free flow

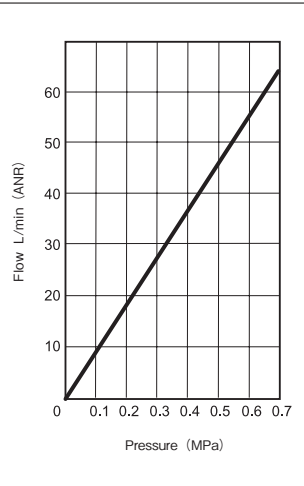

Tube size : 8mm

For controlled flow

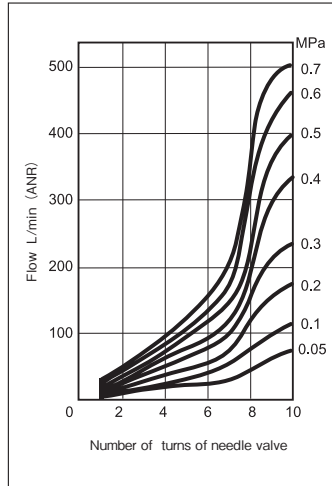

For free flow

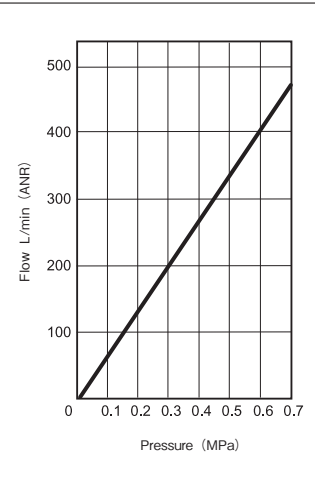

Tube size : 4mm

For controlled flow

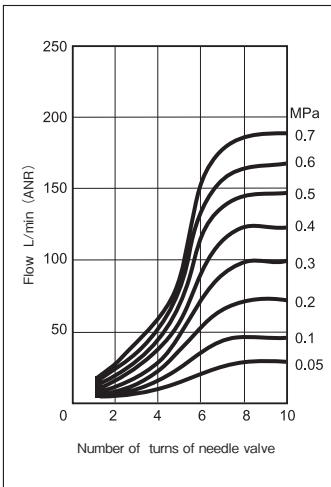

For free flow

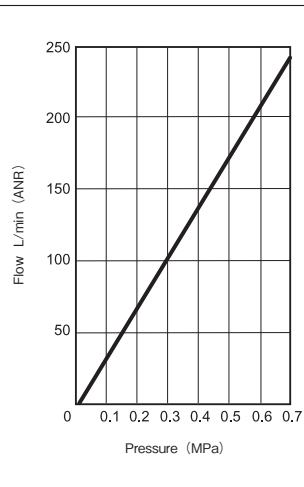

Tube size : 10mm

For controlled flow

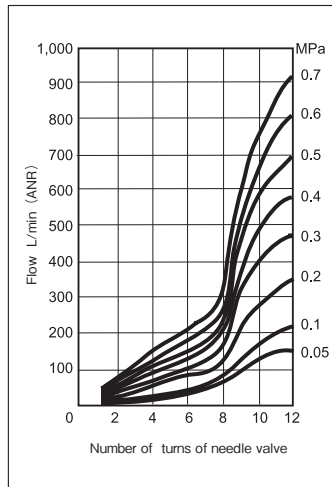

For free flow

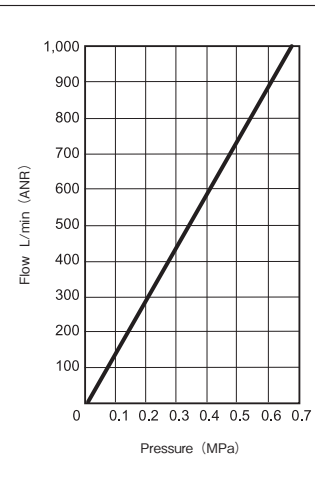

Tube size : 6mm

For controlled flow

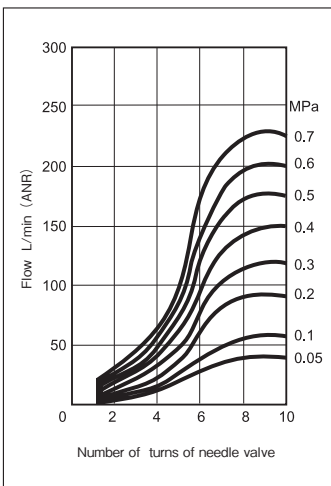

For free flow

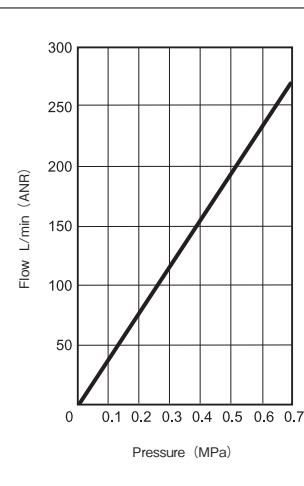

Tube size : 12mm

For controlled flow

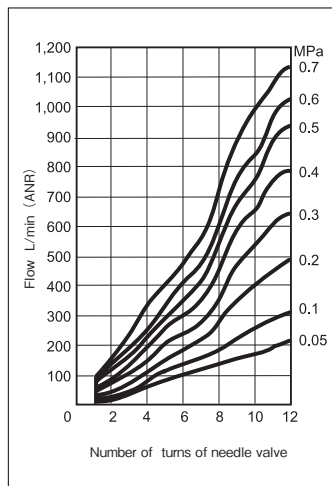

For free flow

